

Radiation-Tolerant Custom Made Low Voltage Power Supply System for ATLAS/TileCal Detector

I.Hruska ^a, B.Palan ^a, F.Calheiros ^b, S.Nemecek ^a, Z.Kotek ^a, J.Palacky ^c, L.Price ^e, M.Lokajicek ^a,
A.Tikhonov ^d and A.Solin ^d

^aInstitute of Physics, Na Slovance 2, Prague 8, Czech Republic

^bCERN, CH-1211 Geneva 23, Switzerland

^cCharles University, Faculty of Nuclear Physics, Prague, Czech Republic

^dNC HEP, Minsk, Belorussia

^eArgonne National Laboratory, Argonne, Illinois, USA

ivan.hruska@siemens.com

bpalan@cern.ch

Abstract

This paper describes custom made Low Voltage Power Supply (LVPS) system developed for the ATLAS – TileCal detector of the LHC (The Large Hadron Collider) particle accelerator at CERN, Geneva. The system is based on the use of only COTS (Commercial of The Shelf) components, is qualified to be radiation tolerant up to 40krad, and can operate in external DC magnetic field above 0.02 Tesla. The LVPS design described in this paper has been developed and produced for the ATLAS TileCal detector during the years 2001 – 2007.

of the radiation field around detector with safety factors (SF) defined by the ATLAS radiation policy group [2].

Table 1: LVPS estimated required radiation doses.

	Worst simulated numbers for LVPS	SF	Test doses required	
TID	5.31E-01	70	37.17	krad per 10 years
NIEL	3.18E+11	20	6.36E+12	n/cm ² per 10 years
SEE	8.74E+10	20	1.75E+12	p/cm ² per 10 years

I. INTRODUCTION

Particle detectors of the LHC accelerator had been designed to have integrated electronics. One of the main constraints for this decision was extreme amount of data necessary to manage and then reduce dataflow as close as possible to the detectors. The other problem started to rise some ten years ago on how to power such electronics. Operating environmental conditions for the front-end electronics and also for the integrated power supplies are exceptional in such case and constituting lot of constraints for designers. The power supply system for TileCal calorimeter has to supply 256 front-end electronic blocks called drawers. It is 3 meters long structure sitting inside the detector iron ended up by so called “finger” – the only possible space for LVPS in the vicinity of TileCal.

II. SYSTEM REQUIREMENTS AND FEATURES

LVPS design requirements came from the required voltage and current levels to be supplied to the TileCal distributed front-end electronics [1]. Operating environmental conditions of power supplies sitting inside of the particle detector are exceptional. Continuous radiation exposure, very limited space, only water cooling available, and an external DC magnetic field from superconducting magnets - used for particle separation - are the big constraints for electronic design.

The level of total estimated radiation dose (TID), neutron (1MeV equiv.) and proton fluencies for LVPS are listed in Table 1. Values were computed from simulations

Magnetic field inside the drawer finger region has been also simulated using TOSCA and MARMAID simulation tools [3]. Even though the finger LVPS region is well shielded area (>20mm of iron) some residual DC field still would have an impact to the operation of magnetic components, such as power transformers and ferrite chokes. Figure 1 shows the effect of internal magnetic field to the ferrite cores as they are placed inside LVBOX. The maximum computed DC magnetic field is less than 0.02Tesla (200 Gauss).

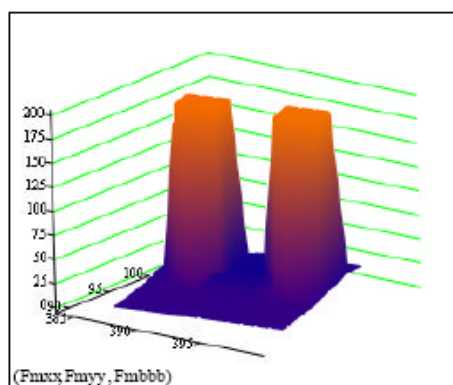

Figure 1: Distribution of magnetic field within the LVPS location window with max field distortion from ferrites - units in Gauss.

However, real radiation and magnetic field levels will be possible to measure only during the real run of the LHC accelerator. Thus, the LVPS design requirements included

simulated values multiplied by safety factors SF according to the ATLAS rules.

Other key LVPS requirements and features:

- Limited size of LVBOX 170 x 170 x 170 mm.
- Water cooling inside power supply
- Reliable remote independent On/Off for two functional parts of drawer (HV side and DIGITIZER).
- Remote monitoring of basic electrical parameters and temperatures.
- Remote trimming of all output voltages within +/-0.5V.
- Local protection circuits, such as OverVoltage, OverCurrent, Over Temperature (OVP, OCP, and OTP).
- Safety Interlock circuit.
- Increased reliability for power and signal distribution system due to limited-access during operation.

III. LVPS SYSTEM TOPOLOGY

Electrical and environmental requirements led to classical design using high efficiency DC/DC converters being radiation and magnetic field tolerant. Application of methods for safety reliable systems (redundancy, design safety factors, interlocks, and malfunction protection circuits) and minimization of sensitive magnetic components have been applied.

Two stage distributed power system with a certain level of immunity against radiation and magnetic field has been designed, see Figure 2.

The first power stage consists of AC to DC conversion of three phase 3 x 230VAC input into 200VDC output voltage distributed from 24 HPS1 power supplies, sitting in USA15 shielded cavern. One HPS1 unit [4] contains three channels. Each 200VDC channel simultaneously supplies four LVBOX finger power supplies - Power Branch.

The 200VDC power cables 70-100 meters long go from USA15 room to the ATLAS detector cavern. Then they are splitted inside of four distribution boxes and continue to the four TileCal partitions to supply 64 LVBOXes each.

The Tile Calorimeter front-end electronics (drawers) are powered by 256 custom-made power supplies called LVBOXes. Each LVBOX contains eight 150W DC/DC single-output modules transforming 200VDC input into various independent low voltage outputs (+3.3V, +/-5V, +/-15V). Each LVBOX is water cooled.

To ensure reliable LVPS control in the radiation environment a microprocessor circuitry can not be used inside the LVBOX. That is why a local control and communication board, so called ELMB [5] was applied. The ELMB incorporates CAN Bus protocol for communication. It enables to monitor behavioural parameters of each DC/DC converter, such as I_{in} , I_{out} ,

V_{in} , V_{out} , two on board temperatures, sense lines, and enables to trim V_{out} of each DC/DC module - Brick.

Integral part of the LVPS remote control are so called AUX Boards installed in USA15 shielded cavern. Each card remotely controls 4 LVBOXes, and delivers additional independent auxiliary power and interlock signals for each LVBOX and ELMB board inside. It also contains monitoring circuitry for all auxiliary voltages and currents and DC/DC converter synchronization circuits for better EMC behaviour of LVBOXes. In total, 64 pieces of AUX Boards are necessary to control the whole power system of TileCal.

All 256 LVBOXes, 64 AUX Boards, and twenty-four HPS1 200V power supplies are interconnected together by means of CAN bus, and are controlled by 4 PCs. OPC servers for CANBUS and MODBUS with custom monitoring and control software are installed. Different users can operate and monitor the TileCal power system over ETHERNET/TCPIP network from any place.

Finally, four ATLAS DSS - LVPS Interlock Cards (not shown in Figure 2) were designed to immediately stop the operation of the whole TileCal LVPS in case of cooling water leak or shutdown. One Interlock Card can enable/disable operation of six HPS1 200V power supplies and 16 AUX Boards, thus 64 LVBOXes – one whole partition.

IV. UNIVERSAL DC/DC CONVERTER - BRICK

Full custom design uses only COTS (Commercial Off The Shelf) components. The universal PCB design enables to select three brick versions of various outputs (+3.3V, +5V, or 15V) by means of only several components exchange.

The DC/DC converter is based on LT1681 chip [6, 11] dual transistor forward converter in a current mode control with switching frequency of 300 kHz. The brick frequency can be synchronized with other DC/DC modules inside LVBOX. This topology, described on Figure 3, minimizes number of semiconductor components and also number of necessary windings of the transformer. Input voltage (200V) and power MOSFET transistors were chosen with regards to SEE/TID dependency on V_{sd} , V_{th} , and $R_{ds}(ON)$ parameters [7]. The maximum delivered output power is 150W.

High switching frequency led to very small size of brick transformer (16 x 10 x 25 mm) and possibility using Printed Circuit Board windings. The transformer was custom designed in-house using special PCB manufacturing technology developed in collaboration with PRINTED [8].

Due to minimization of brick dimensions an innovative cooling of the DC/DC converter was applied by means of custom Al_2O_3 ceramic spacers. Space for components is then doubled saving the PCB size

The DC/DC converters demonstrate [9] high efficiency of energy conversion: 72% for 3.3V @10A I_{out} , 85% for 5V version @10A, and 82 % for 15V version @6A.

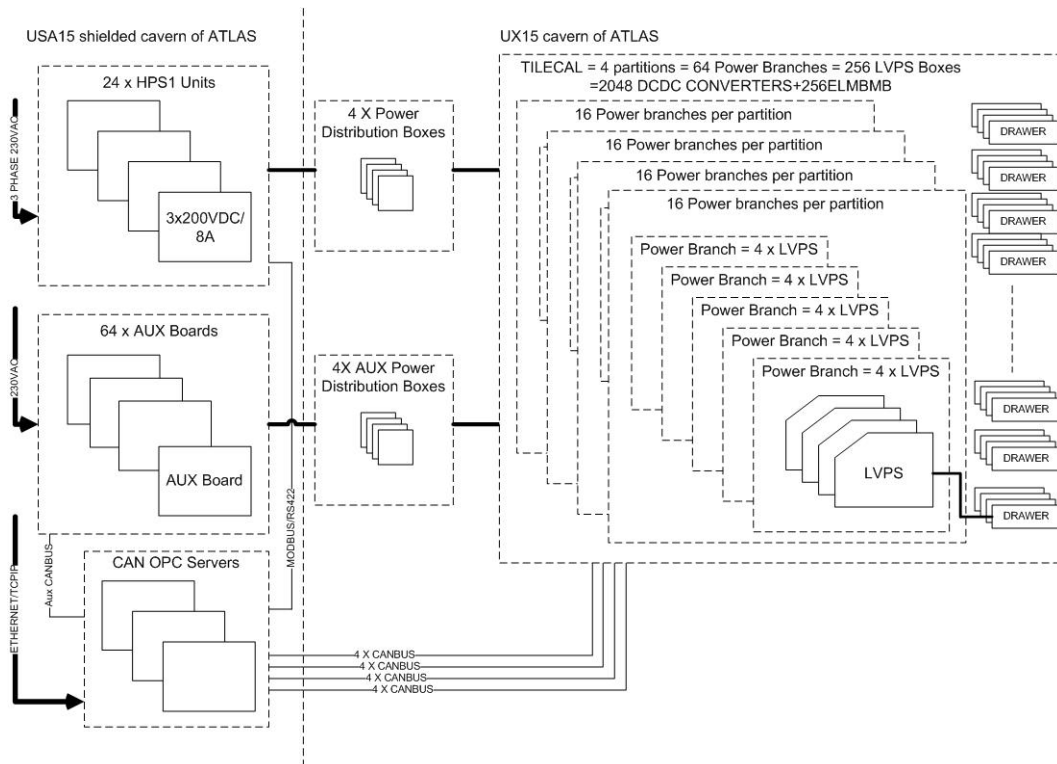

Figure 2: System topology of the TileCal LVPS System.

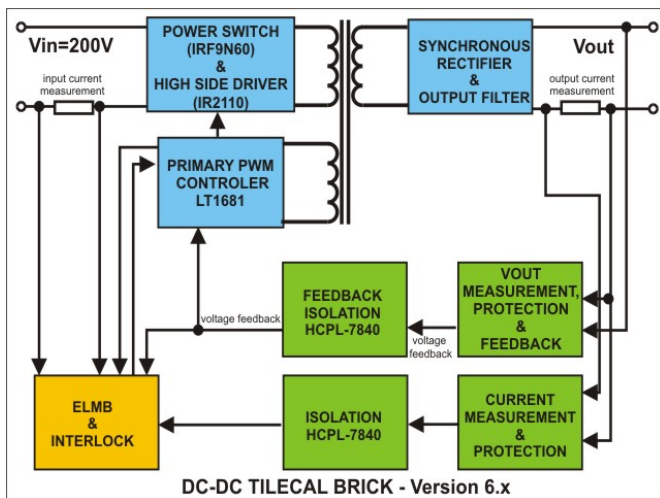

Figure 3: TileCal DC-DC converter block scheme.

Brick has integrated remote control and measurement circuitry for both input (I_{in}/V_{in}) and output (I_{out}/V_{out}) parameters. Moreover, three temperature sensors are also present to control brick cooling. The V_{out} voltage can be trimmed in the required range, see Table 2. This feature enables a remote V_{out} correction during radiation degradation of the Brick. The trimming, sensing and remote monitoring of the converter are carried out by ELMB module [5]. Integrated brick features are also active OverTemperature, Overcurrent and Overvoltage protection circuitries [10]. Photo of the TileCal DC/DC converter is shown in Figure 4.

Extensive irradiation test campaigns of COTS components and of the brick prototype were performed at PSI, Villigen, CH (protons 2002, 2003, 2004), at CERN (neutron P2B 2004, TCC2 SPS tunnel 2002, 2003

campaigns), Saclay (Co60 gamma test 2003) and at INT Portugal NIEL tests in 2003 [9]. Also behavioral tests with brick and LVBOX were carried out in a DC magnetic field up to 1000Gauss in all three space directions x,y,z.

Experimental results demonstrated that bricks and ELMB motherboards can work together without problems up to 20krad TID. The Brick radiation tolerance is even higher reaching 35-38krads. Bricks are also designed to be operational in external DC magnetic field without damage. Magnetic field decreases the efficiency caused by DC magnetization of the power transformer ferrite core. The decrease of the DC/DC converter efficiency measured at CERN magnet with external B field at 200 Gauss was max -1.5%, and at 500 Gauss was -3%, respectively [9].



Figure 4: TileCal DC/DC converter 80x80mm.

V. LVBOX

The LVBOX is plugged into the finger of TileCal. It is only the part of LVPS system exposed to radiation and magnetic field in the ATLAS cavern. Each LVBOX contains eight galvanically separated DC/DC converters – bricks, see required voltage and current levels in Table 2. The LVBOX also contains the so called ELMB Motherboard, ELMB module [5], 200VDC distribution Fuse-Board, internal cable set, and chassis and water cooled heatsink, see photo in Figure 5.

The ELMB Motherboard and ELMB module are connected to 8 DC/DC converters for remote control and monitoring. The LVBOX of each Tile detector module has to deliver average power of 300W.

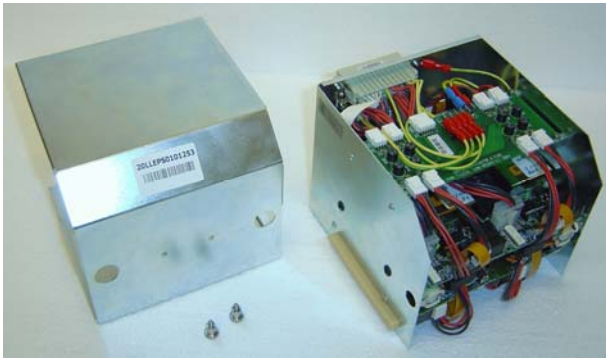

Figure 5: Photo of assembled LVBOX (170x170x170mm).

LVBOX chassis is made by nickel coated iron sheet. All input/output/control signals are connected via a plug-in common connector HARTING. On the LVBOX front side are only two leak-less in/out connectors for water cooling.

Special extraction and handling tools were designed to simplify the insertion/extraction, manipulation and the transport of LVBOXes.

Table 2: Voltage and current ranges required for one drawer.

Drawer Levels	V range[V]	I range [A]
M15HV	-14.45 ~ -15.65	0.15 ~ 1.9
P15HV	14.45 ~ 15.65	0.15 ~ 0.4
P5HV	5.0 ~ 6.0	0.1 ~ 0.3
P15MB	14.45 ~ 15.65	0.2 ~ 0.6
M5MB	-5.0 ~ -6.0	3.3 ~ 6.7
P5MB	5.0 ~ 6.0	6.6 ~ 13.3
P5DIG	5.0 ~ 6.0	3.3 ~ 6.7
P3DIG	3.15 ~ 4.0	1.7 ~ 5.6

VI. HPS1 200V POWER SUPPLY

The block of HPS1 [4] power supplies can deliver total power of 110 kW for 256 LVBOXes placed around the TileCal calorimeter partitions.

The HPS1 consist of 3 independent AC/DC converters - output units – each delivering 200VDC/8.5A (1700W) from three phase mains 3 x 230VAC. Each output voltage can be trimmed and enables the use of sense wires to compensate voltage drop along output cables. Outputs have over/under-voltage and over-current protections. Central control unit controls 3 output units and works also as the user interface with touch screen display and as a remote

control interface. Each unit can be remotely supervised via RS422 network and by using MODBUS protocol. The unit is 4U height, see Figure 6. All twenty four HPS1 units are installed in USA15 cavern. The power supply was developed in collaboration with TESLA Company [12].



Figure 6: HPS1 200V DC power supply photo.

VII. LVPS AUX BOARD

The Auxiliary (AUX) Board (6U height, see Figure 7) generates all auxiliary signals and additional voltages for one branch of 4 LVBOXes. The input is standard 230VAC mains. The board consists of twelve isolated power supplies. Four for the ELMB motherboards (trimmed between 6.8 - 14.5V), then four for ELMB chips (6.8 - 14.5V) and four for Start-up signals (15 - 25V) for LVPS bricks. It also contains current loop sources for LVBOX HV/DIG side remote on/off control. Part of the AUX board is as also interlock circuitry. Additional AUX Board circuit is a clock generator and distributor for synchronous operation of all DC/DC converters of 4 supervised LVBOXes.

The AUX board is controlled via its own ELMB [5] module using custom made version of ELMB firmware. All AUX boards are connected into separated CAN bus network nodes. Their control is embedded into the general remote control system.



Figure 7: LVPS AUX board photo.

LVPS INTERLOCK BOARD

The LVPS interlock board receives the ATLAS DSS cooling interlock signals. In case of interruption of water cooling to the Tile Calorimeter, one LVPS Interlock Board will disable operation of 64 LVBOXes. It is hardwired together with 16 channels of 200VDC HPS1 bulk power

supplies and 16 AUX Boards. Finally, four LVPS Interlock Boards are capable to switch off the whole LVPS system, which is 256 LVPS supplies, 24 HPS1, and 64 AUX Boards.

VIII. LVPS REMOTE CONTROL

The TileCal LVPS is computer controlled and on-line monitored system. Communication between 256 LVBOXes, 64 AUX Boards and HPS1 is covered and supervised by general SCADA system communicating via OPC servers with the hardware – ELMBs via CANBUS and HPS1 via MODBUS. System uses several separated CANBUS or RS422 based MODBUS networks.

LVBOXes and AUX boards apply ELMBs as basic modules using CANOpen protocol. This enables to monitor each individual parameter of the system i.e. any of 2048 Brick output voltages or currents, to control the overall performance of the LVPS, and global sequential start-up and shutdown procedures.

The LVPS remote control software is written in PVSS environment. Network topology interconnects 4 CAN bus branches per partition of 64 LVBOXes. There are 16 CANBUS networks in total and used for LVPS inside TileCal cavern, plus some additional CAN bus networks to control AUX boards in USA15 control room.

IX. LVPS PRODUCTION

Production of LVPS system started in 2005. TileCal requirements were to produce 256 LVBOXes (that means 256 chassis, 2048 DC/DC bricks, 256 ELMB modules + Motherboards, 256 Fuse Boards, cable sets, screws etc.), 64 AUX Boards, and 24 HP1 200V power supplies. During 3-10years of operation one should estimate additional 20% of spare components for easy maintenance and exchange in case of malfunction.

Twenty four HPS1 power supplies were ordered from TESLA Company [12]. The whole quantity of PCBs for 300 LVBOXes has been produced in Printed [8] (PCB) and assembled in HC Electronics [13]. These two companies produced i.e. 2400pcs of DC/DC converters, 300pcs of ELMB Motherboards, 300 Fuse Boards, 70pcs of AUX Boards and 4 Interlock cards. Cable and transformer assemblies were produced in the workshops of Institute of Physics, Prague [15].

Our team designed and built a complete set of automated testers for all LVPS production components:

- Power transformer tester set (inductances, ratio, HV isolation)
- Low voltage Brick tester (PINFIELD)
- Brick Performance tester (BURN-IN)
- ELMB Motherboard tester
- AUX Board tester
- LVBOX Quality Assurance tester
- Universal Cable testers, plug-ins, and so on.

All tested LVPS components have their own unique bar code sticker. Quality reports and measured data were put on-line into the LVPS database. The LVPS system then offers full traceability and performance history [14].

CONCLUSIONS

The presented project and its solutions described in this paper were designed, developed and produced from scratch satisfying challenging ATLAS TileCal detector specifications. The system was built during the years 2001 – 2007. Authors would like to thank to all project participants who helped bringing this project to its successful end.

X. REFERENCES

- [1] "Design of the front-end analog electronics for the ATLAS tile calorimeter", K. Anderson et al., Nucl. Instr. and Meth. A, Vol. 551 (2005), pp. 469-476.
- [2] "Estimation of Radiation Background, Impact on Detectors, Activation and Shielding Optimization in ATLAS", S. Baranov et al. ATL-GEN-2005-001, CERN technical report, 13 January 2005.
- [3] "3D Magnetic Field Calculations in the Finger Region of the TileCal", S.B. Vorobjtsov et al., ATL-TILECAL-99-019, CERN technical report, 13 October 1999.
- [4] "High power supply HPS1 Operational Manual", TESLA Hloubetin, Prague, CZ, technical manual, 2005.
- [5] "The Embedded Local Monitor Board (ELMB) in the LHC Front-end I/O Control System", B. Hallgren, 7th Workshop on Electronics for LHC Experiments, LECC2001.
- [6] <http://www.linear.com>
- [7] "Single Event Burnout in DC- DC Converters for the LHC Experiments" B. Allongue, G. Berger, F. Faccio, W. Hajdas, C. Rivetta, RADECS 2001.
- [8] <http://www.printed.cz>
- [9] Production Readiness Review of LVPS design, LVPS Meeting, CERN/ATLAS/TileCal, 10 Dec 2004.
- [10] "Specifications for the Modification of the ATLAS TileCal Bricks for Low Voltage Power Supplies", B. Palan, L. Price, G. Drake, CERN ATLAS Draft report, Dec 29, 2006.
- [11] "Radiation and magnetic field tolerant 150W DC/DC converter brick", I. Hruska, CERN-ATLAS-TileCal internal technical datasheet, 2006.
- [12] www.tesla.cz
- [13] www.hcelectronics.cz
- [14] www.particle.cz/work/tiledb/
- [15] www-hep.fzu.cz