

# 3.3V AND 5V BRICKS SCHEMATICS, V.6.5

CUSTOM DESIGN, PRINTED LTD.

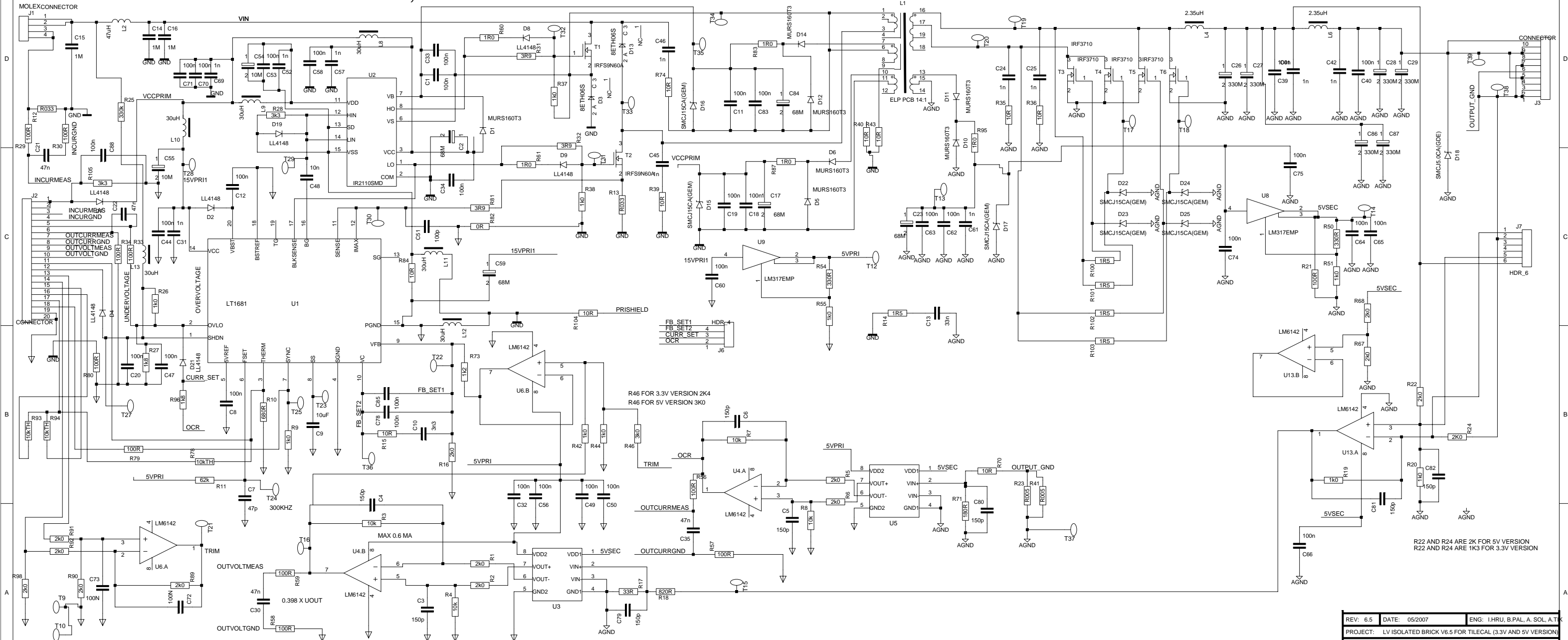

REV: 6.5	DATE: 05/2007	ENG: I.HRU, B.PAL, A.SOL, A.T.K
PROJECT: LV ISOLATED BRICK V6.5 FOR TILECAL (3.3V AND 5V VERSION)		
COMPANY: CERN/ATLAS/TILECAL/LVPS GROUP		
ADDRESS: GENEVE		
CITY: GENEVE		
COUNTRY: SWITZERLAND		
INITIAL	2.6.2004	PAGE: 1 OF: 1

R22 AND R24 ARE 2K FOR 5V VERSION  
R22 AND R24 ARE 1K3 FOR 3.3V VERSION