

# 15V BRICKS SCHEMATICS, REV.6.5.4A

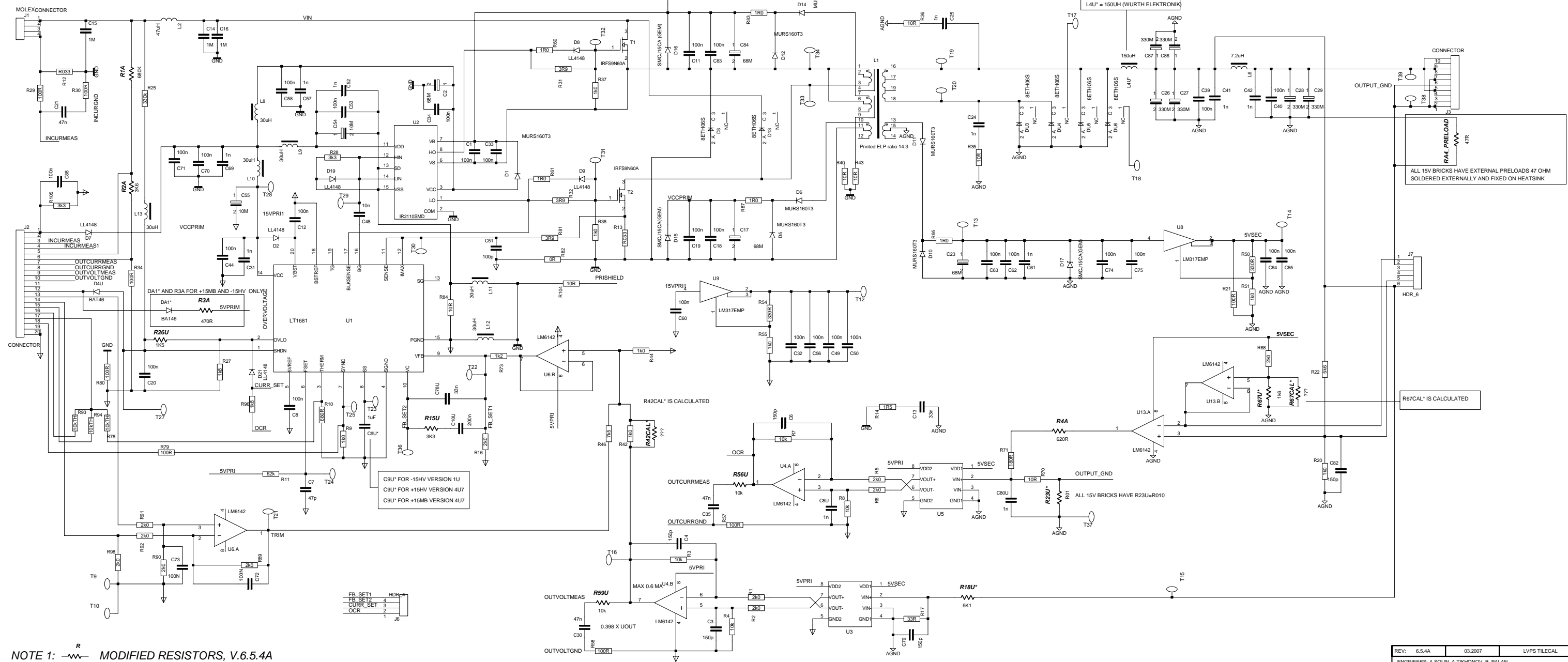

NOTE 1:  $\overline{R}$  MODIFIED RESISTORS, V.6.5.4A

NOTE 2: R42CAL\* AND R67CAL\* ARE CALCULATED BY CALC.XLS

REV: 6.5.4A	03.2007	LVPS TILECAL
ENGINEERS: A.SOLIN, A.TIKHONOV, B.PALAN		
PROJECT: 15V BRICKS, V6.5.4.A PRODUCTION VERSION 2007-2008		
COMPANY: CERN/ATLAS/TILECAL/LVPS GROUP		
ADDRESS: CH-1211, GENEVE 23		
CITY: GENEVE		
COUNTRY: SWITZERLAND		
TITLE_UPDATE	INITIAL 27.03.2002	PAGE: 1 OF: 1