

REV: 3	DATE: 15.8.2005, OCT2006	ENG: IVAN HRUSKA, B.PALAN
PROJECT: AUXILIARY BOARD V2.4 FINAL		
COMPANY: CERN		
ADDRESS: PH-UAT/ATLAS/TILECAL		
CITY: GENEVA		
COUNTRY: SWITZERLAND		
INITIAL	1.4.2005	PAGE: 1 OF: 11

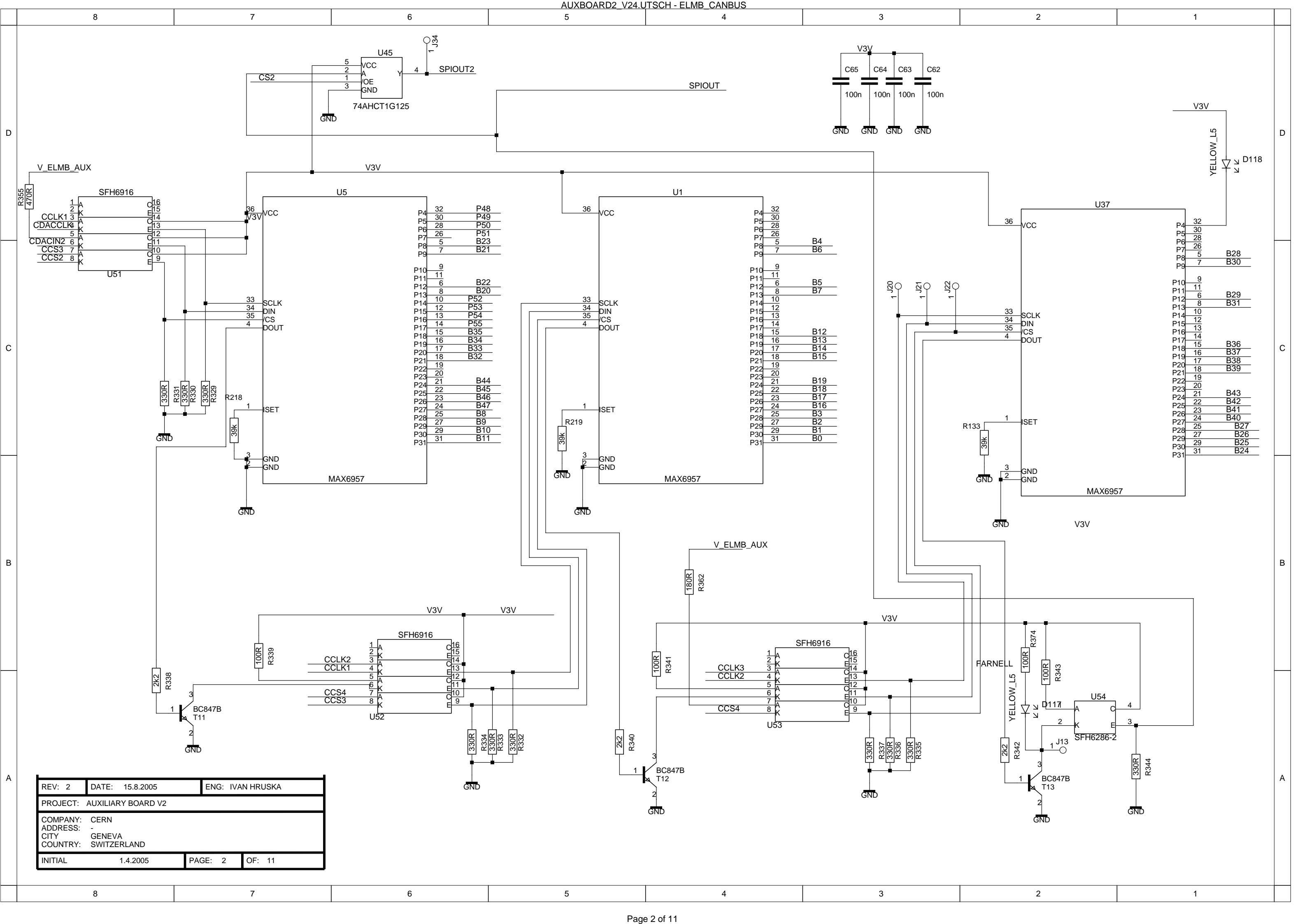

REV: 2	DATE: 15.8.2005	ENG: IVAN HRUSKA
PROJECT: AUXILIARY BOARD V2		
COMPANY: CERN		
ADDRESS: -		
CITY: GENEVA		
COUNTRY: SWITZERLAND		
INITIAL	1.4.2005	PAGE: 2 OF: 11

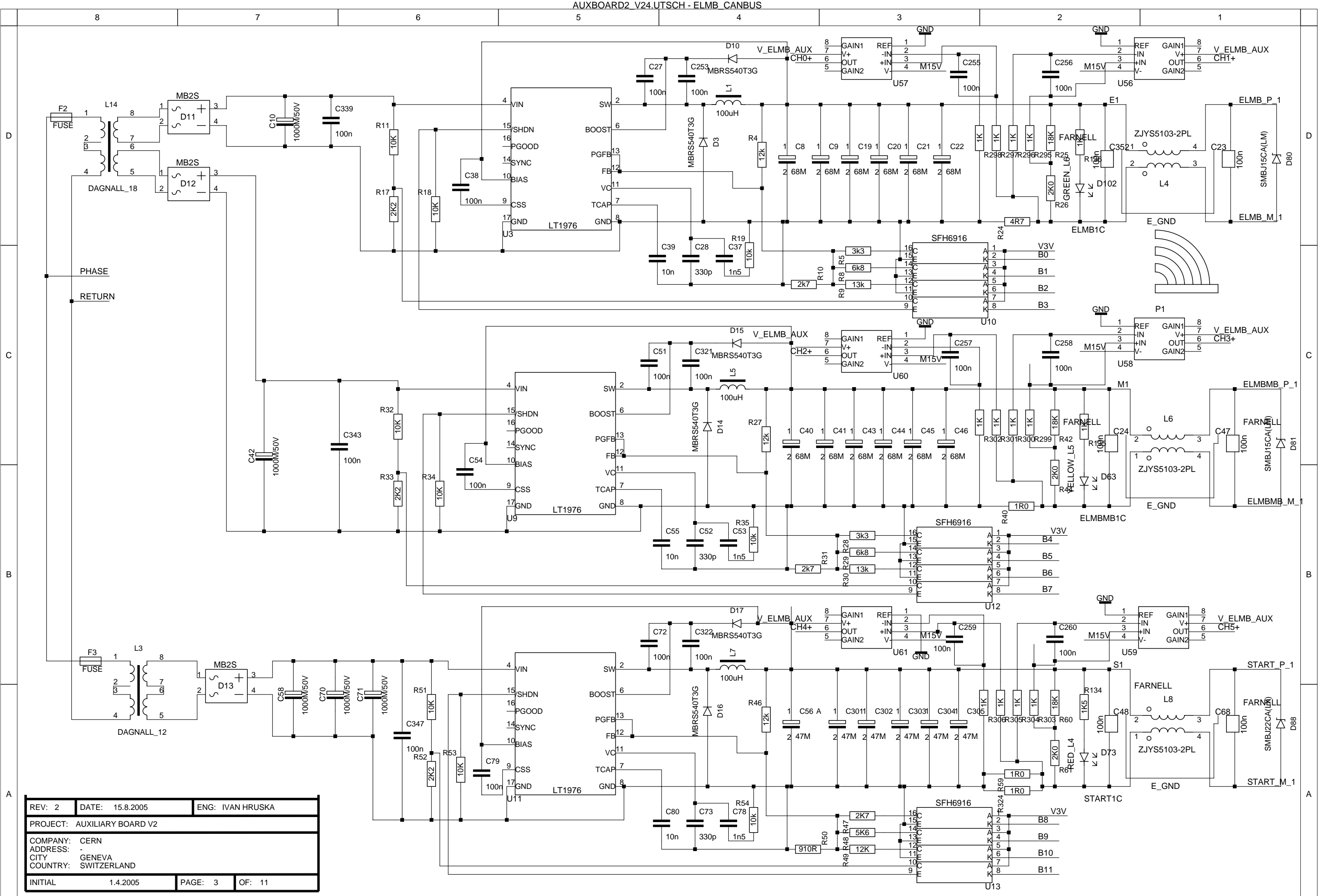

REV: 2	DATE: 15.8.2005	ENG: IVAN HRUSKA
PROJECT: AUXILIARY BOARD V2		
COMPANY: CERN		
ADDRESS: -		
CITY: GENEVA		
COUNTRY: SWITZERLAND		
INITIAL	1.4.2005	PAGE: 3 OF: 11

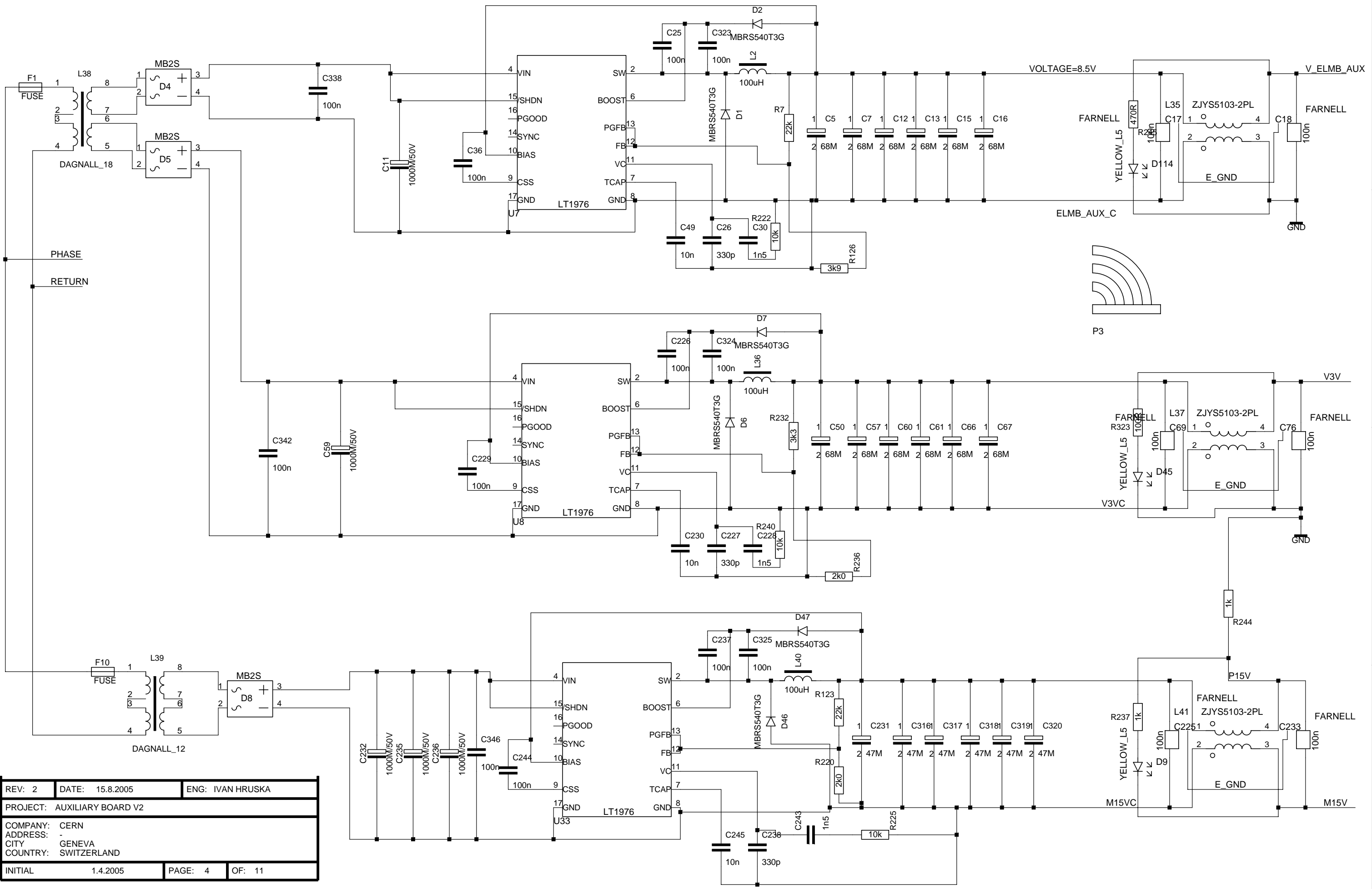

REV: 2	DATE: 15.8.2005	ENG: IVAN HRUSKA
PROJECT: AUXILIARY BOARD V2		
COMPANY: CERN		
ADDRESS: -		
CITY: GENEVA		
COUNTRY: SWITZERLAND		
INITIAL	1.4.2005	PAGE: 4 OF: 11

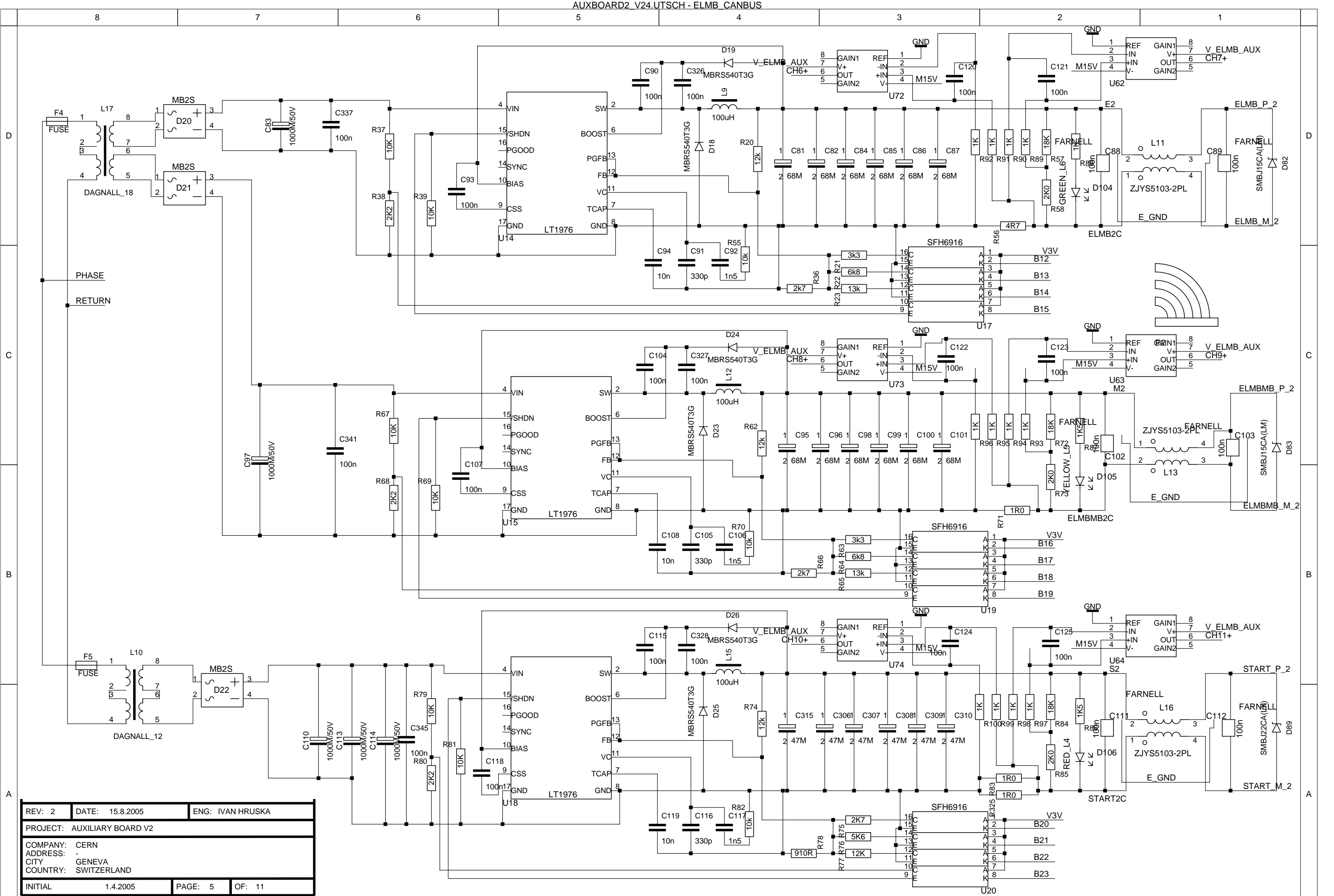

REV: 2	DATE: 15.8.2005	ENG: IVAN HRUSKA
PROJECT: AUXILIARY BOARD V2		
COMPANY: CERN		
ADDRESS: -		
CITY: GENEVA		
COUNTRY: SWITZERLAND		
INITIAL	1.4.2005	PAGE: 5 OF: 11

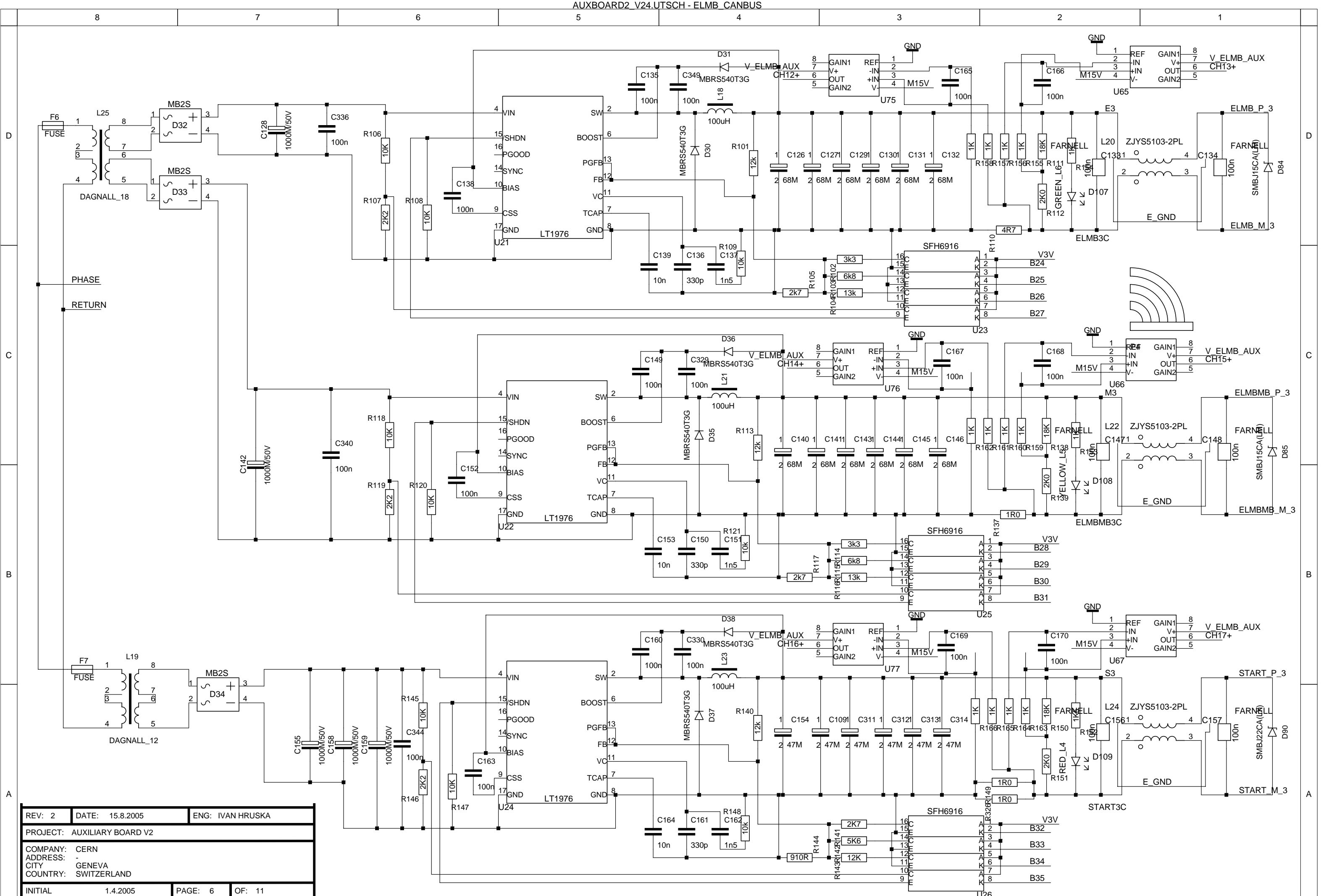

REV: 2	DATE: 15.8.2005	ENG: IVAN HRUSKA
PROJECT: AUXILIARY BOARD V2		
COMPANY: CERN		
ADDRESS: -		
CITY: GENEVA		
COUNTRY: SWITZERLAND		
INITIAL	1.4.2005	PAGE: 6 OF: 11

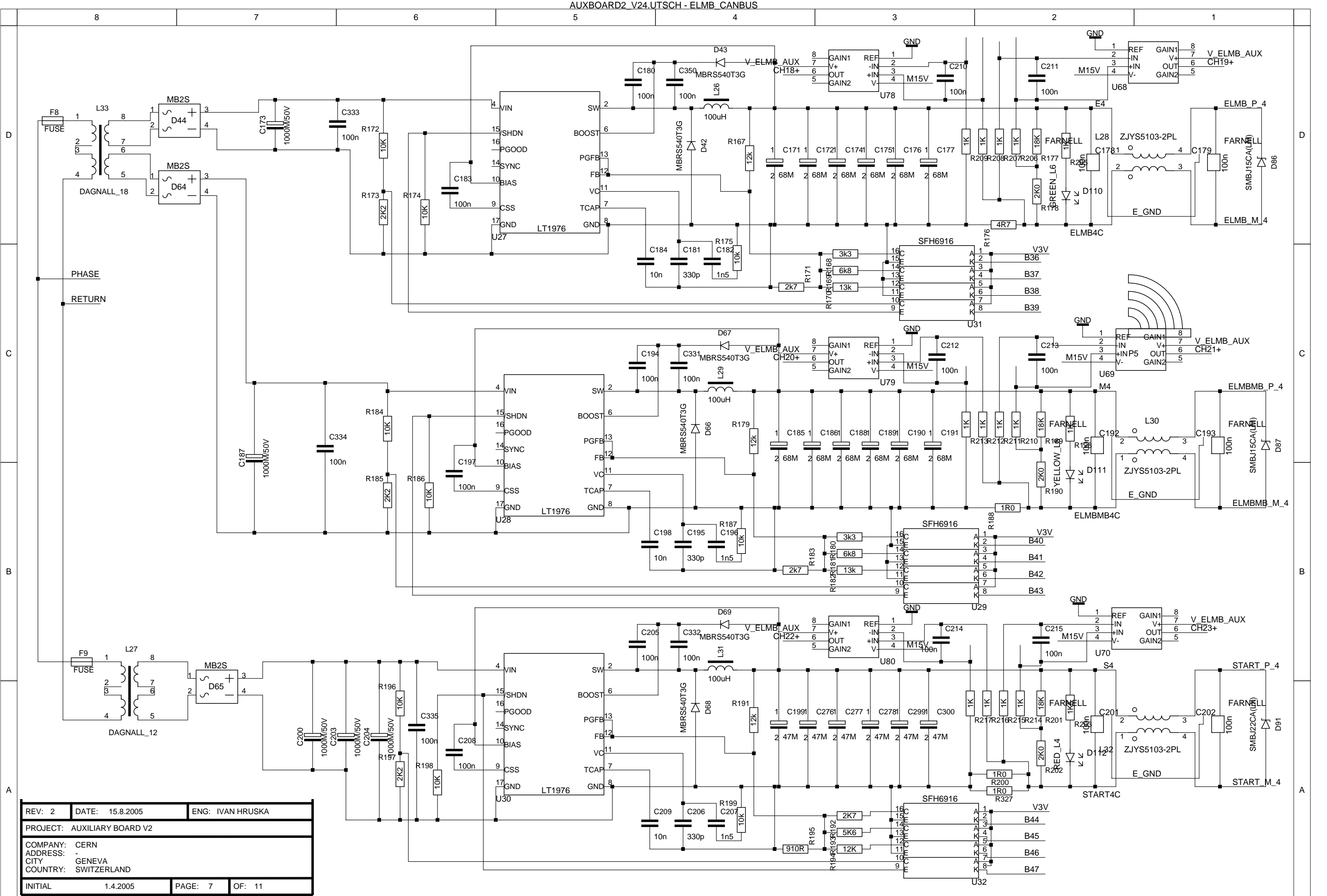

REV: 2	DATE: 15.8.2005	ENG: IVAN HRUSKA
PROJECT: AUXILIARY BOARD V2		
COMPANY: CERN		
ADDRESS: GENEVA		
CITY: GENEVA		
COUNTRY: SWITZERLAND		
INITIAL	1.4.2005	PAGE: 7 OF: 11

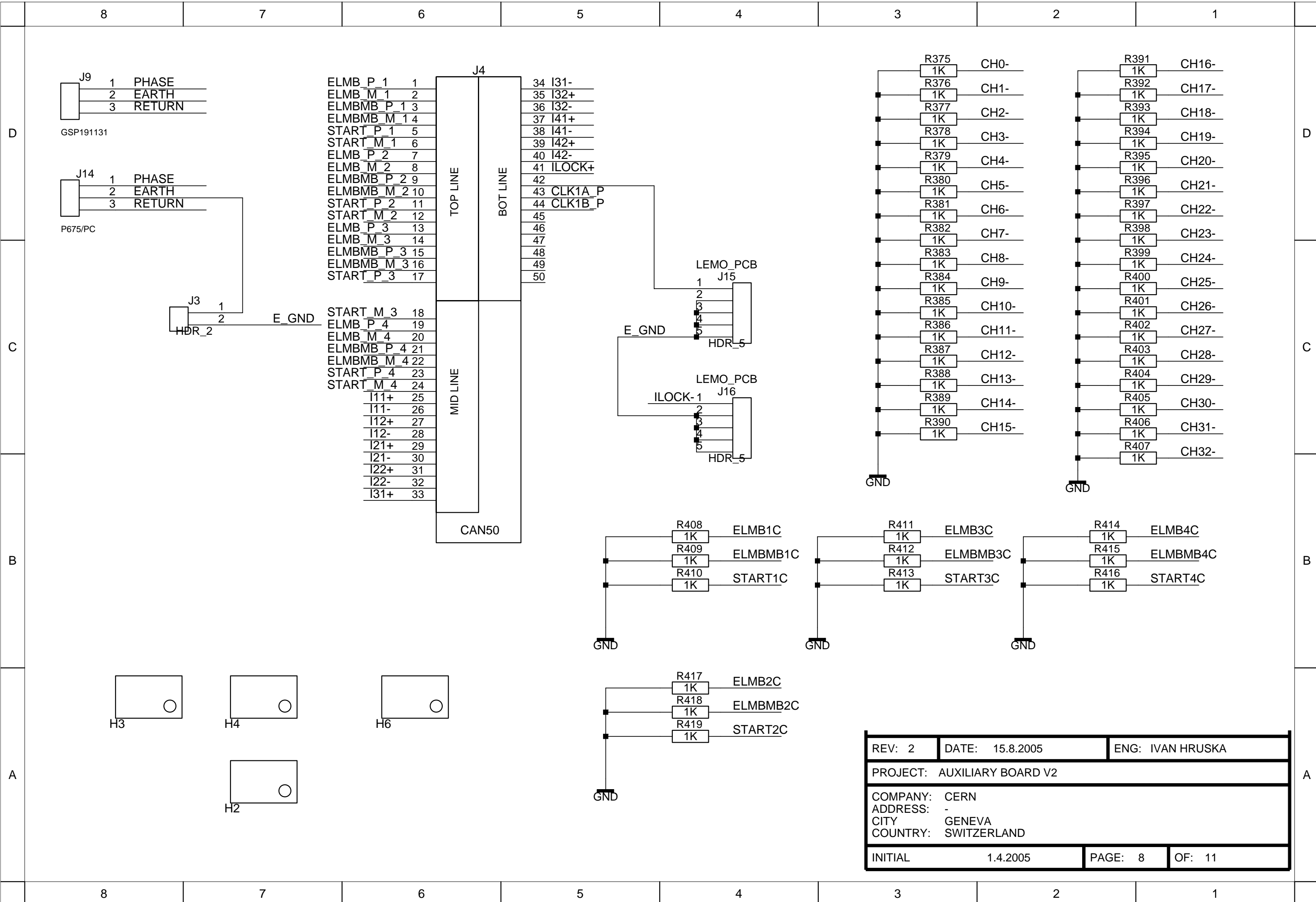

ELMB_P_1	1	34	I31-
ELMB_M_1	2	35	I32+
ELMBMB_P_1	3	36	I32-
ELMBMB_M_1	4	37	I41+
START_P_1	5	38	I41-
START_M_1	6	39	I42+
ELMB_P_2	7	40	I42-
ELMB_M_2	8	41	ILOCK+
ELMBMB_P_2	9	42	
ELMBMB_M_2	10	43	CLK1A_P
START_P_2	11	44	CLK1B_P
START_M_2	12	45	
ELMB_P_3	13	46	
ELMB_M_3	14	47	
ELMBMB_P_3	15	48	
ELMBMB_M_3	16	49	
START_P_3	17	50	
START_M_3	18		
ELMB_P_4	19		
ELMB_M_4	20		
ELMBMB_P_4	21		
ELMBMB_M_4	22		
START_P_4	23		
START_M_4	24		
I11+	25		
I11-	26		
I12+	27		
I12-	28		
I21+	29		
I21-	30		
I22+	31		
I22-	32		
I31+	33		

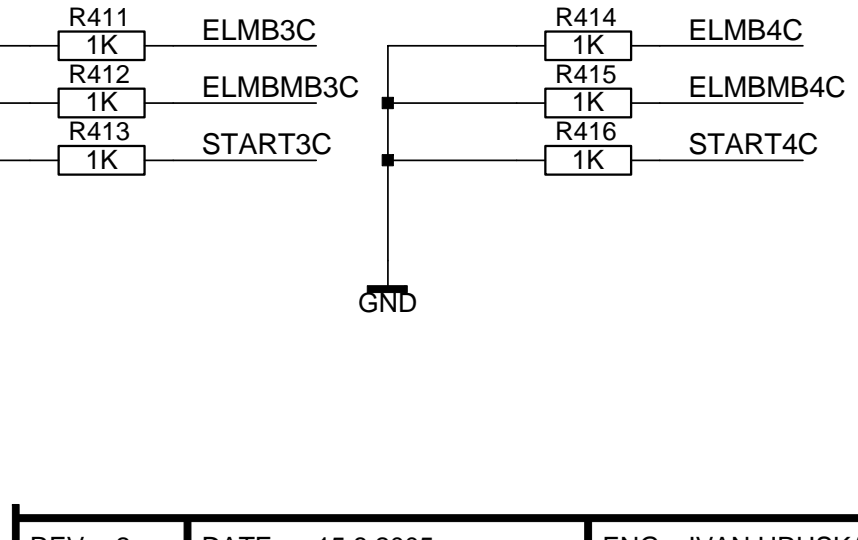
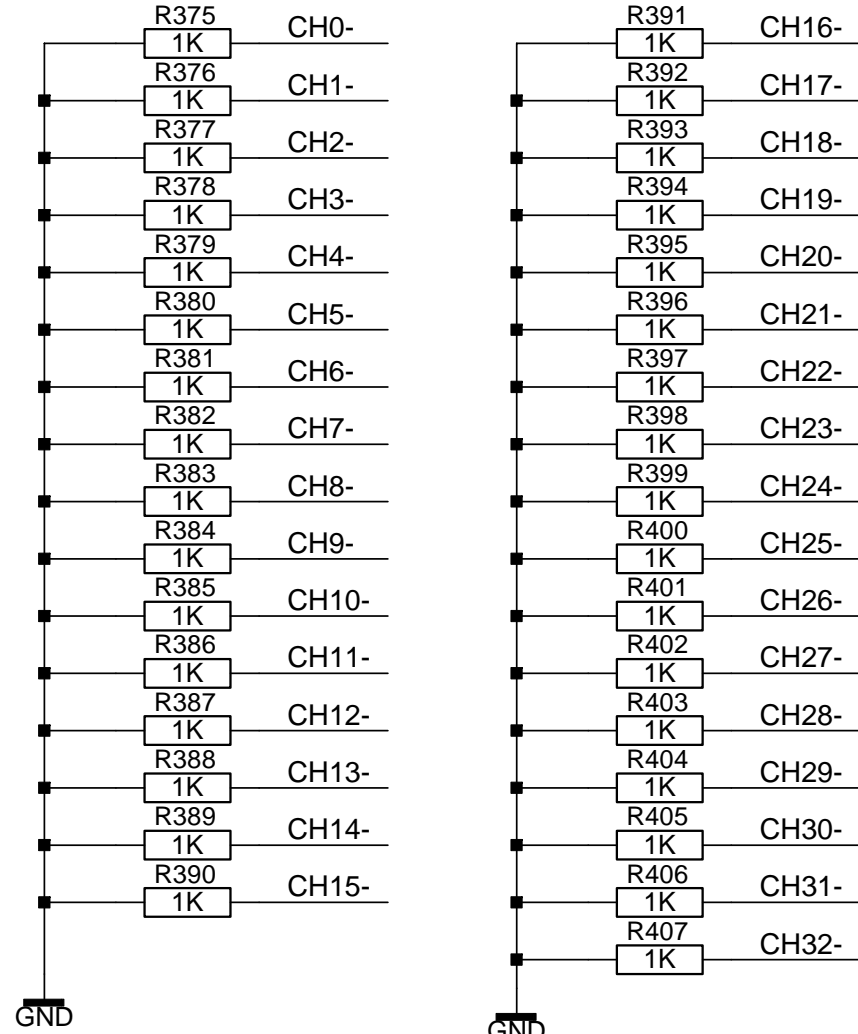

REV: 2	DATE: 15.8.2005	ENG: IVAN HRUSKA
PROJECT: AUXILIARY BOARD V2		
COMPANY: CERN ADDRESS: - CITY: GENEVA COUNTRY: SWITZERLAND		
INITIAL	1.4.2005	PAGE: 8 OF: 11

D

D

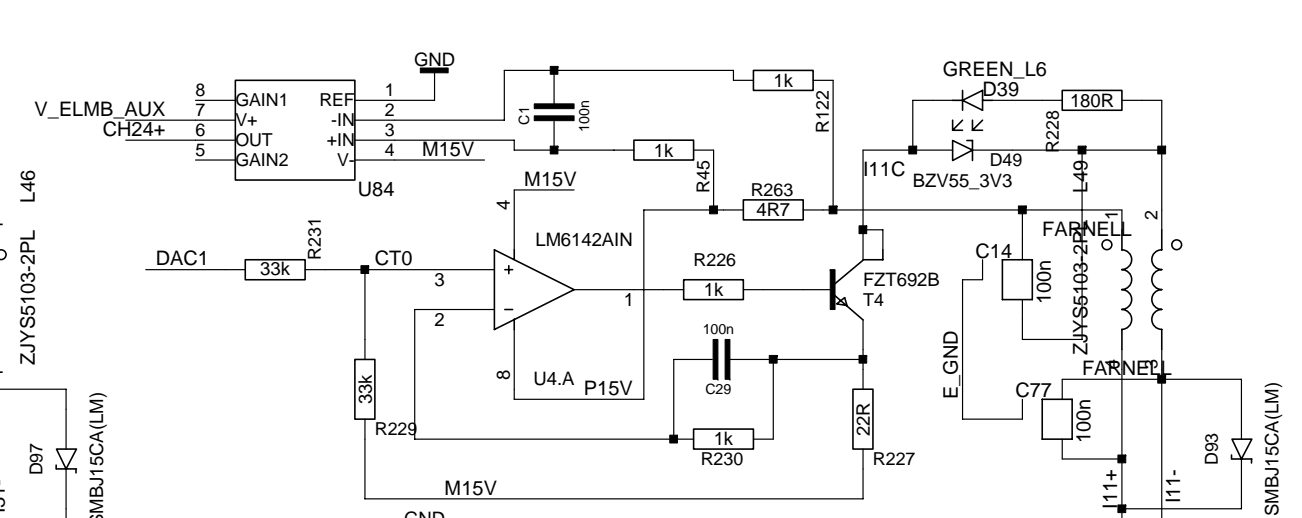
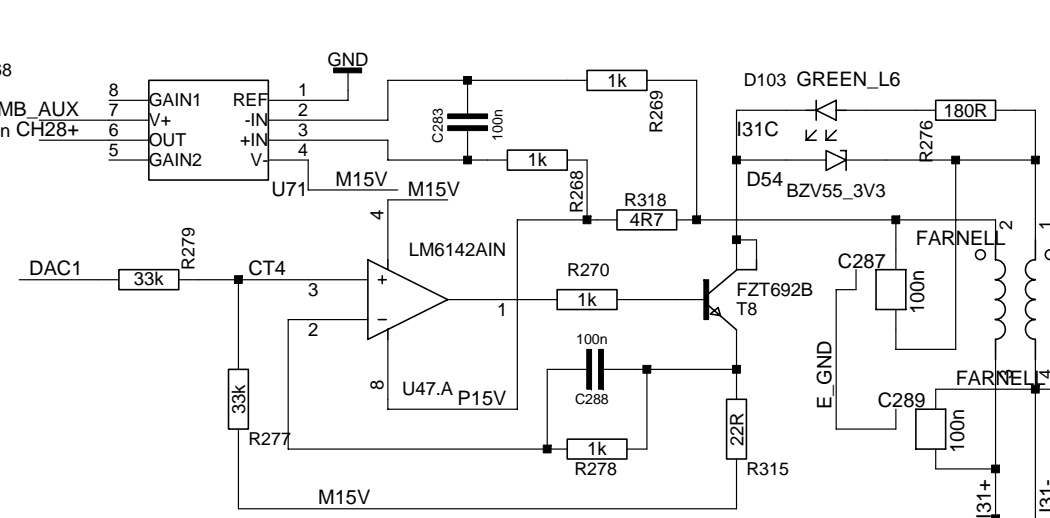
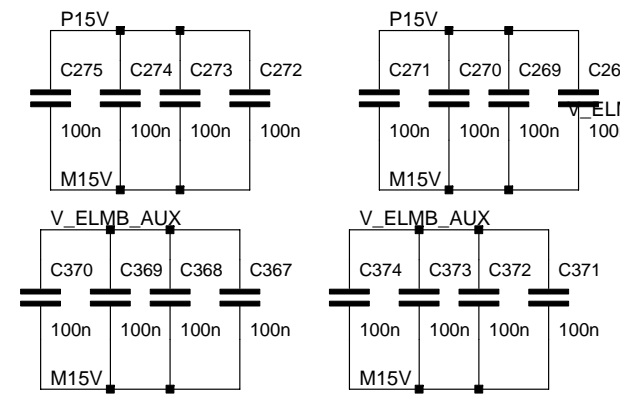

C

C

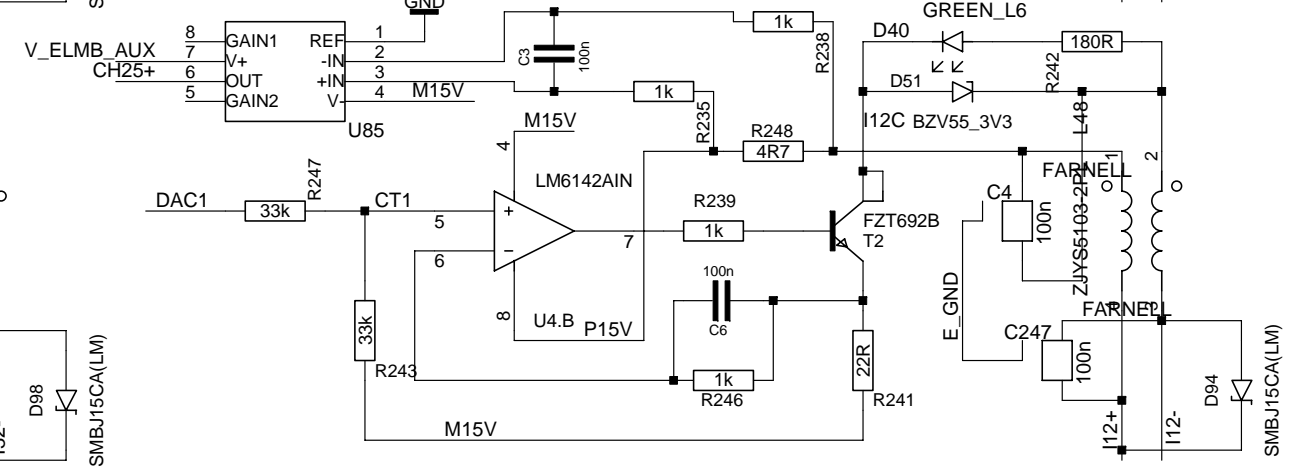
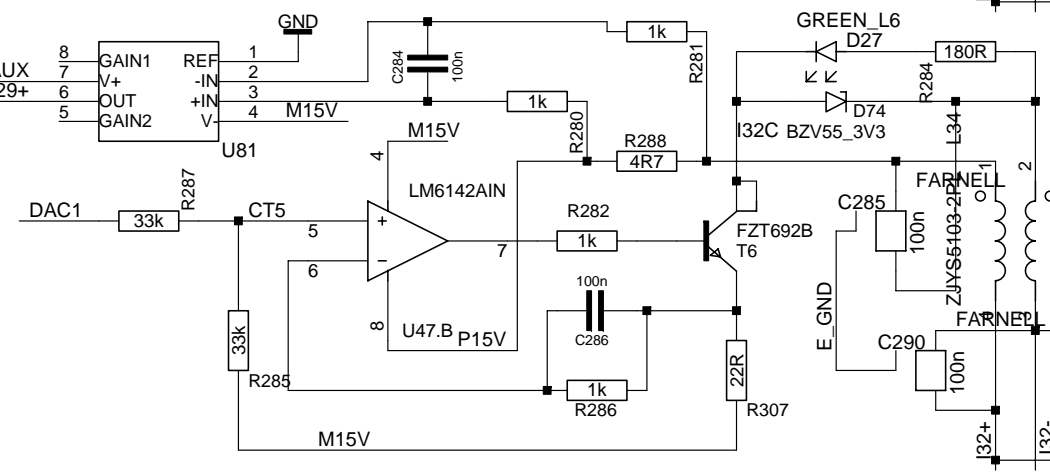
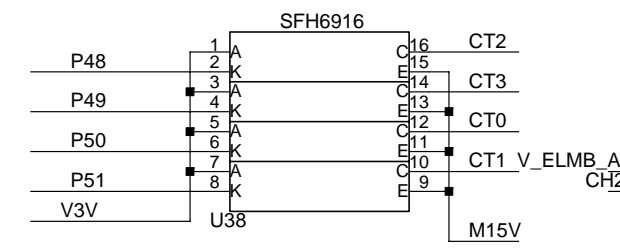

B

B

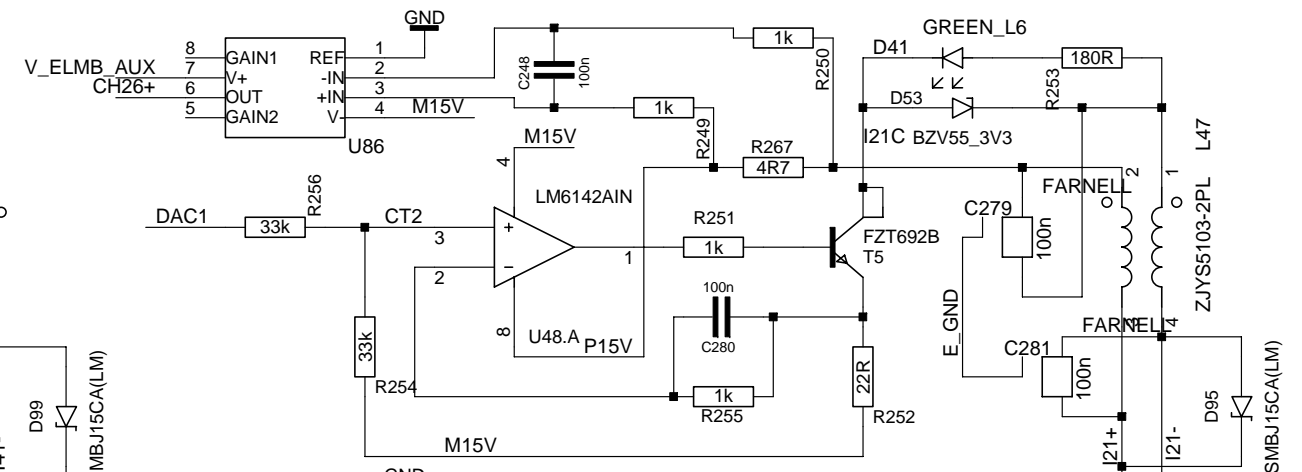
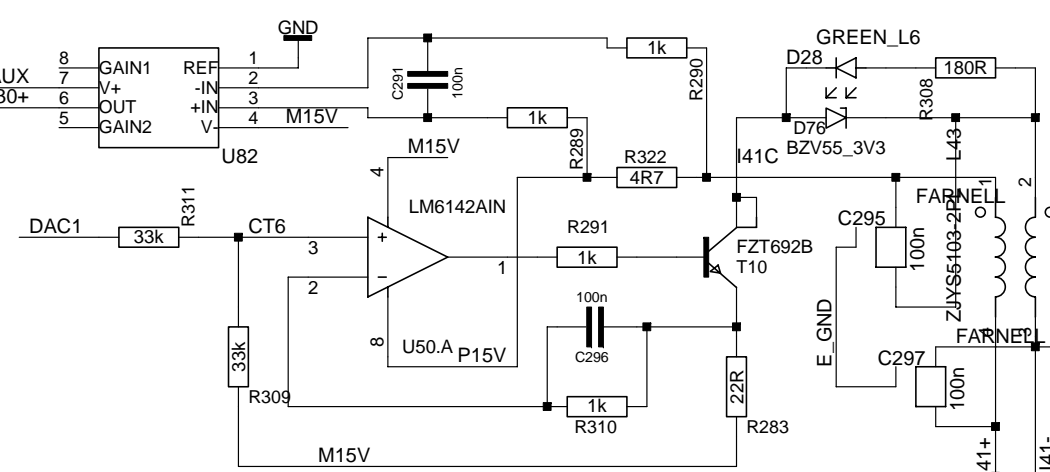
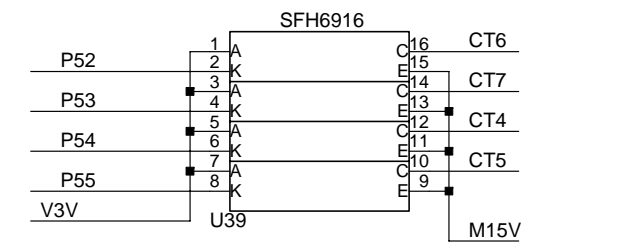

A

A

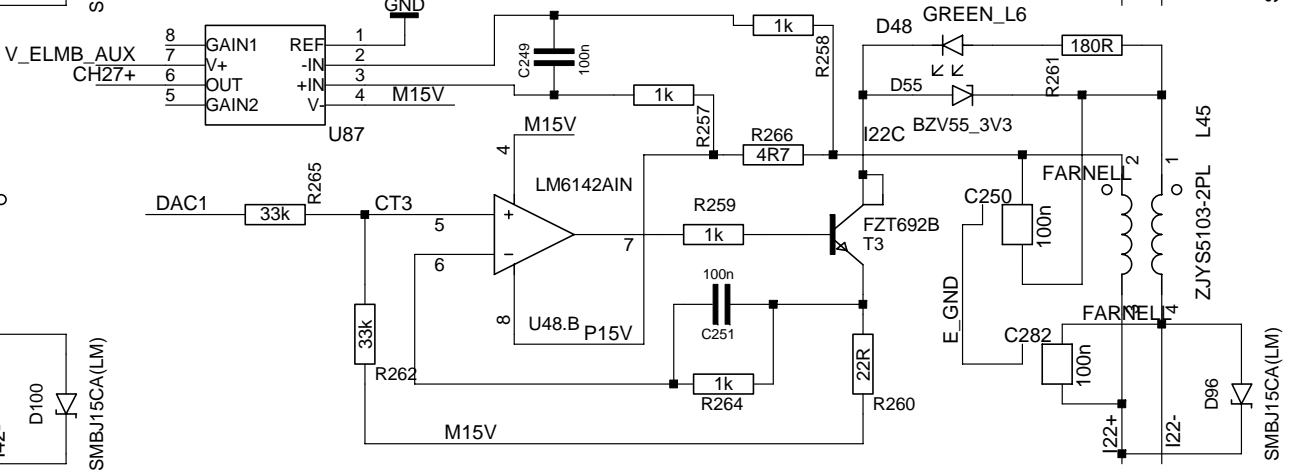
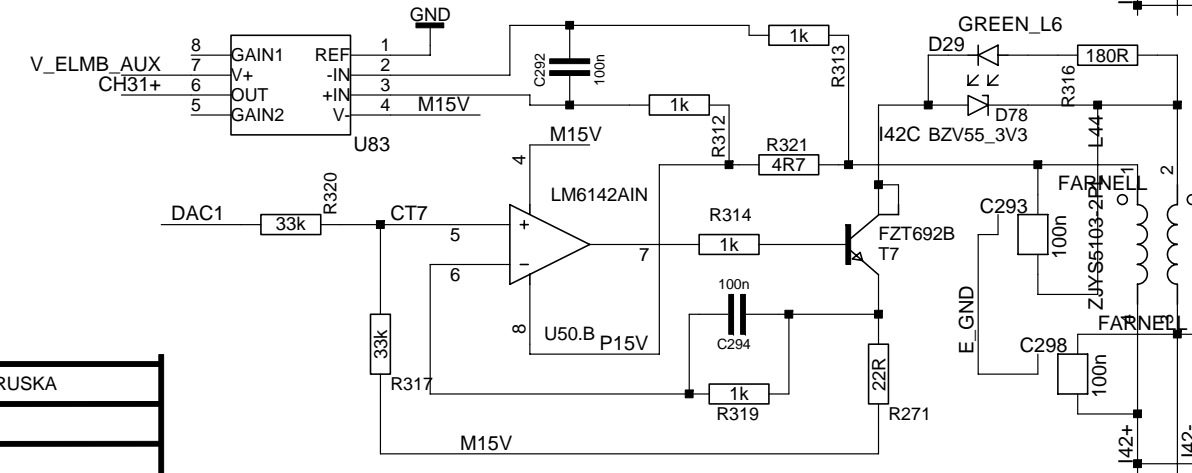
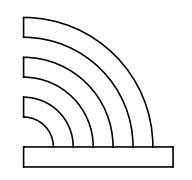
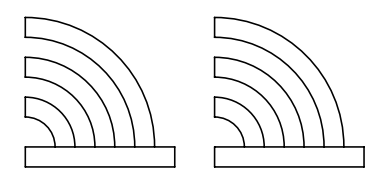
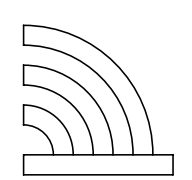
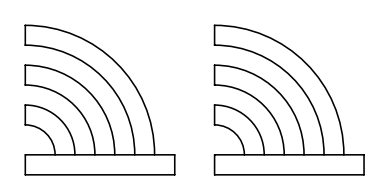

REV: 2	DATE: 15.8.2005	ENG: IVAN HRUSKA
PROJECT: AUXILIARY BOARD V2		
COMPANY: CERN		
ADDRESS: -		
CITY: GENEVA		
COUNTRY: SWITZERLAND		
INITIAL	1.4.2005	PAGE: 9 OF: 11

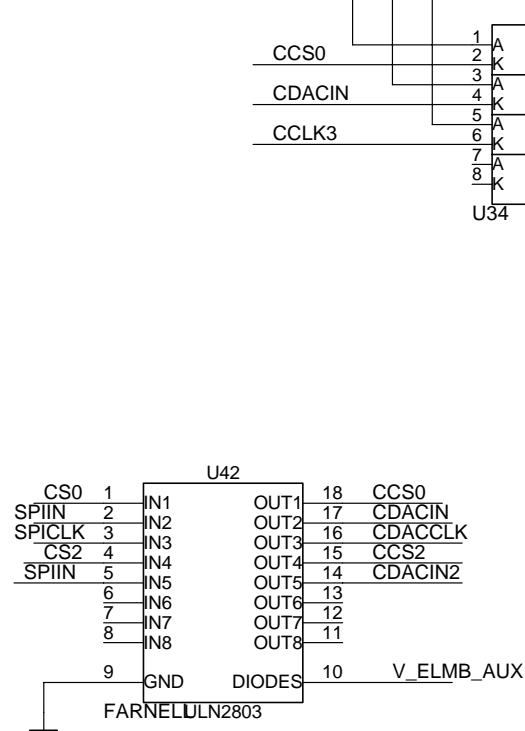
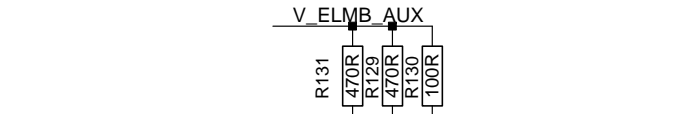
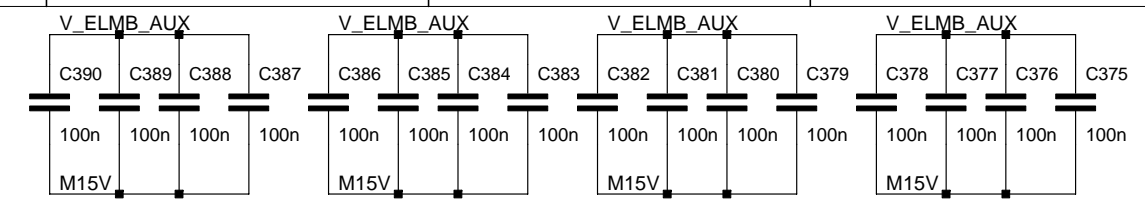
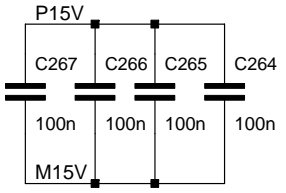
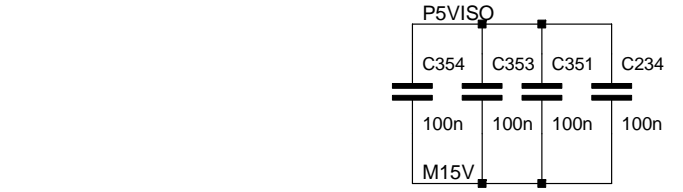
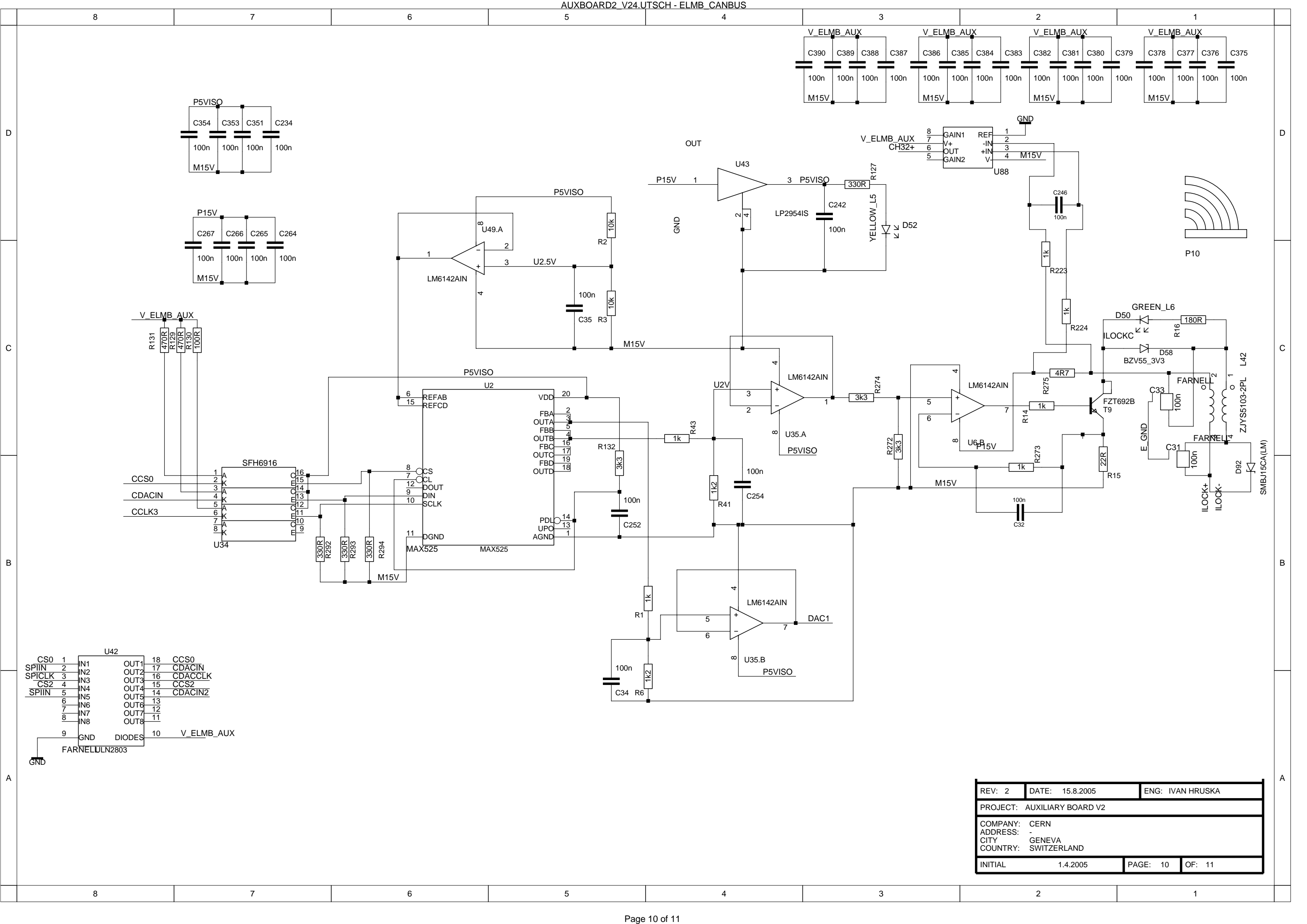

REV: 2	DATE: 15.8.2005	ENG: IVAN HRUSKA
PROJECT: AUXILIARY BOARD V2		
COMPANY: CERN		
ADDRESS: -		
CITY: GENEVA		
COUNTRY: SWITZERLAND		
INITIAL	1.4.2005	PAGE: 10 OF: 11

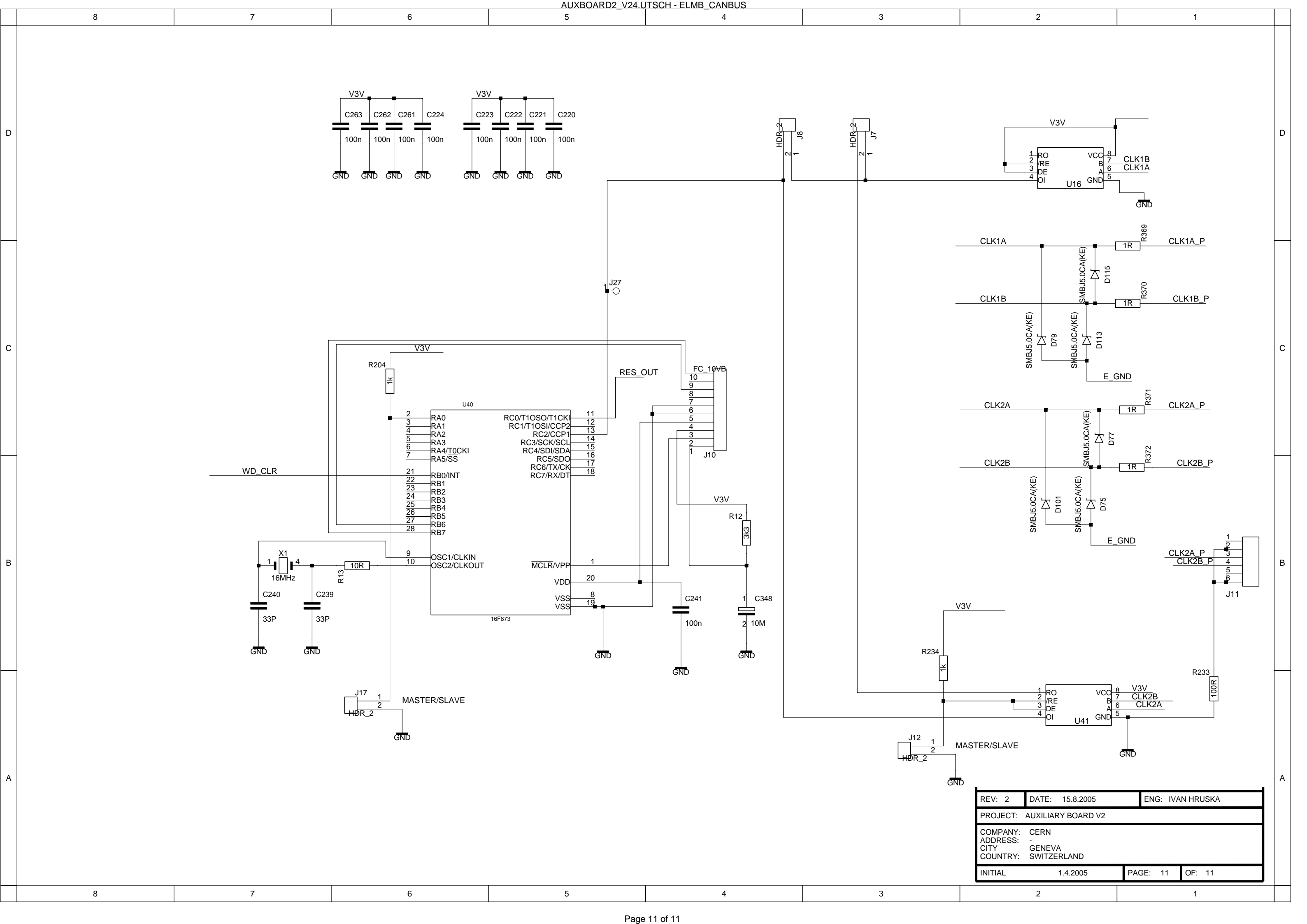

REV: 2	DATE: 15.8.2005	ENG: IVAN HRUSKA
PROJECT: AUXILIARY BOARD V2		
COMPANY: CERN		
ADDRESS: -		
CITY: GENEVA		
COUNTRY: SWITZERLAND		
INITIAL	1.4.2005	PAGE: 11 OF: 11